

Wagon is RIV approved for mainland Europe and UK channel traffic, with the exception of Spain, Portugal and Finland.

2 sliding walls per wagon side give access to the complete floor area from both sides and facilitate the loading/unloading by fork lift truck from ground level.

Wagon has been designed for an even distribution of load on the wagon floor.

The maximum wheel pressure on the floor board is 5 tonnes.

The wagon is fitted with fixing points along both sides for loading security puposes.

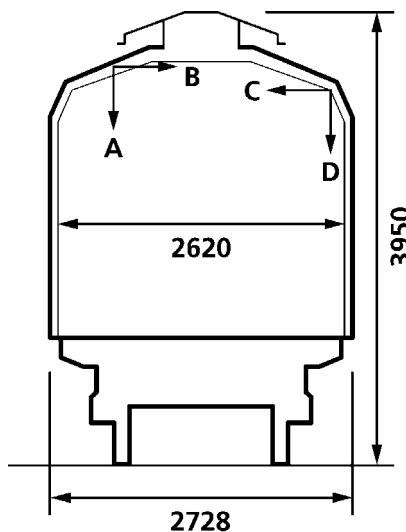
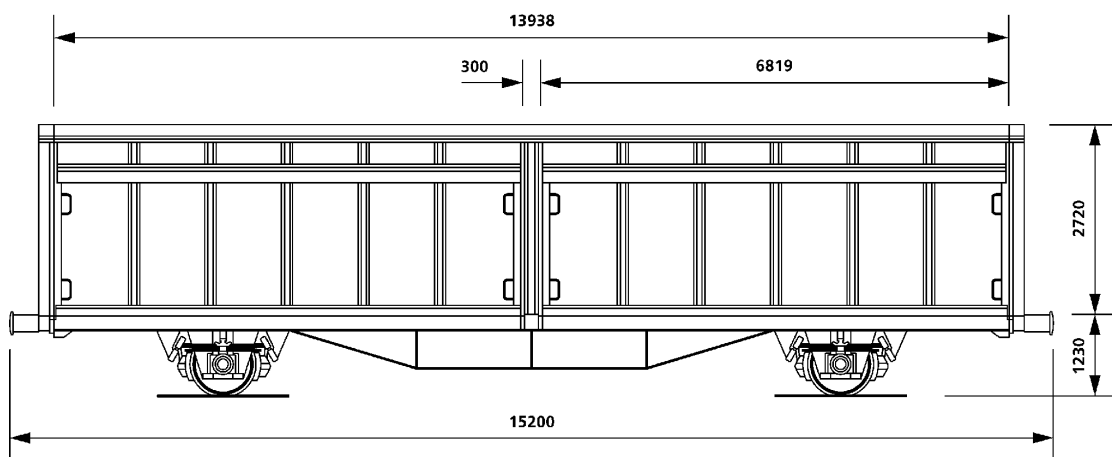

Wagon Data

Overall length (over buffers)	15.200mm
Overall height	3.950mm
Loading length	13.938mm
Loading width	2.620mm
Loading area	36.4m2
Loading capacity	84.7m3
Length of door openings (2 per wagon side)	6.819mm
Height of door openings	2.400mm
Platform height	1.230mm
Tare weight	16.500 kgs
Payload (axle load 20.5 tonnes) ca.	24.500 kgs
Payload (axle load 22.5 tonnes) ca.	28.500 kgs
Minimum curve	75 metres
Maximum speed	100 kph

Refer to separate table for height and width dimensions

Payload	A	B	C	D	
S	15.5	19.5	24.5	28.5	**

GE114CT

Hbfins

