

These wagons were constructed between 1987 and 1989. They are internationally registered with the SNCF for use in mainland Europe only. The wagons meet all existing RIV / RID/ UIC regulations and have been designed primarily for the conveyance of petroleum products.

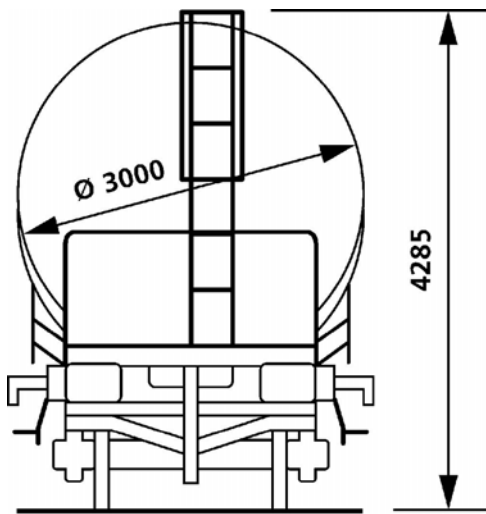
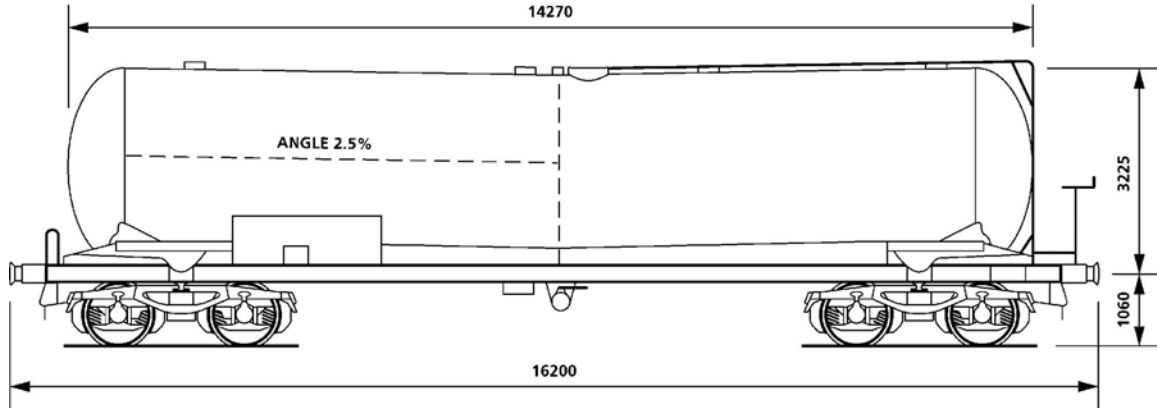

Wagon Data

Overall length (over buffers)	16.200mm
Overall height	4.285mm
Tare weight	24.800kgs
Payload (axle weight 22.5tonnes) ca.	65.200kgs
Minimum curve	35 metres
Maximum speed	100 kph
Maximum capacity	96 m3
Barrel length	14.270mm
Barrel material	Carbon Steel
Barrel drainage slope	2.5%
Barrel pressure (Test)	4.0 Bar
Barrel pressure (Working)	2.66 Bar

Payload	A	B	C	D
S	39.5	47.2	57.2	65.2
120	0.0			

GE307
Petroleum Continental