

These 90 tonne gross wagons were constructed by AFR France between 1988 and 1989. The wagons are UK registered but meet all existing RIV/UIC regulations. They are also approved for Channel Tunnel transit subject to the fitting of retractable canopies. These wagons are designed primarily for the conveyance of aggregates, sand and non-corrosive minerals.

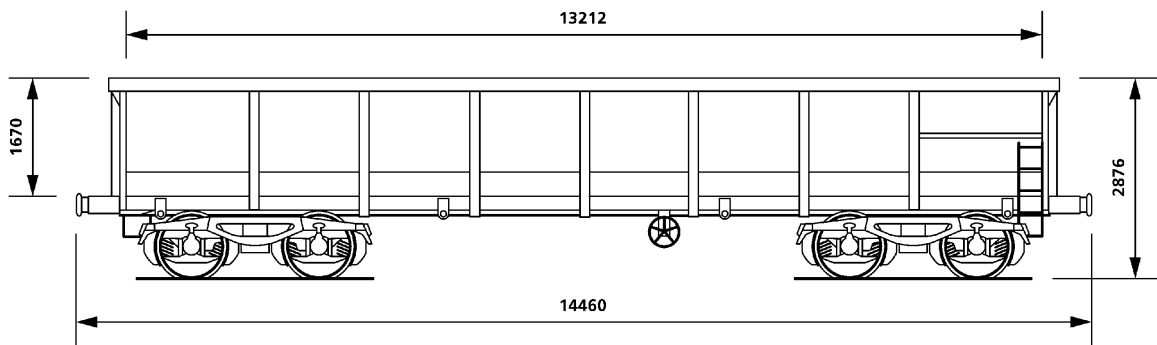

Wagon Data

Overall length (over buffers)	14.460mm
Overall height	2.876mm
Loading length	13.212mm
Loading width	2.272mm
Loading height	1.670mm
Cubic capacity	50m3
Tare weight	21.500 kgs
Payload (axle load 22.5 tonnes)	68.500 kgs
Minimum curve	35 metres
Maximum speed	100 kph

Payload	A	B	C	D
90	42.8	50.8	58.8	68.5
S	42.8	50.8	58.8	
120	0.0			

GE502CT

Aggregate Open Box